

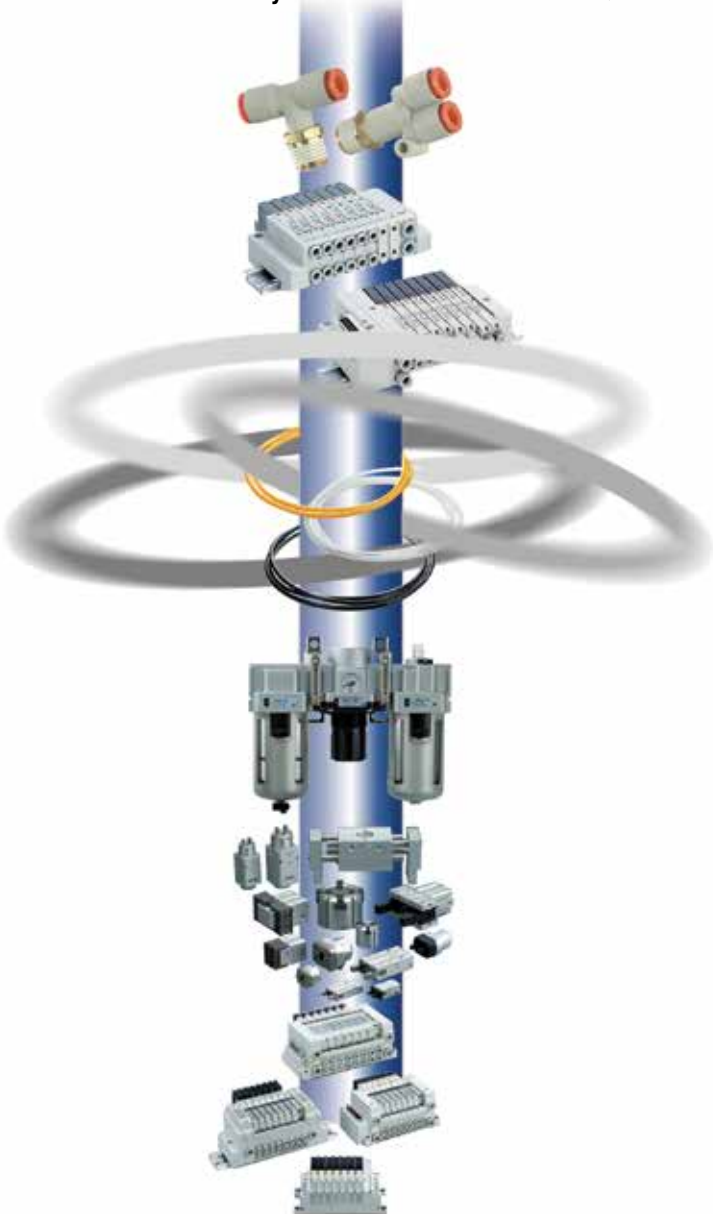

Survival Guide

"The answers to all the crazy Pneumatic and Fluid Power Questions"



Fast Delivery

Regional Distribution Centers
Provide local inventory



Engineered Specials

We offer competitive special products.
We meet customer's request

Made to
Order



Cost Savings

1. Low Power
2. Energy Saving
3. Space Saving



Largest Choice

11,000 basic models & 600,000 variations.



Table of Contents

Unit Conversions	1
Fractional / Decimal / Millimeter Conversion Chart.....	2
Pressure Conversions	3
Cylinder Force Chart	4
Cylinder Speed vs Flow Chart	5
Formulas	6
Valve Sizing	6
Valve Selection	7
Vacuum Cup Sizing	8
Sizing Vacuum Ejectors	8 to 10
Pipe Thread Quick Reference	11
Installation Guide for Valves	12
Directional Control Valves	13 & 14
Product Data Codes	15
Cylinder Part Number Building Information	16
Crossing Over a Cylinder	17
Valve Part Number Building Information	18
Vacuum Order Sheet	19
Auto Switches	20
Pressure Switches and their Simplified Operation	21
NEMA Ratings (Electrical Enclosures)	22
IP Ratings (Electrical Enclosures)	22
How to Order (Series KQ2- New)	23
FRL Cheat Sheet	24

Unit Conversions

Metric to English

Multiply ▽	By ▽	To Obtain ▽
Length:		
µm	0.0394	mil
mm	0.0394	in
cm	0.3937	in
m	3.2810	ft
Area:		
mm ²	0.0016	in ²
cm ²	0.1550	in ²
m ²	10.764	ft ²
Volume:		
mm ³	6.10x10 ⁻⁵	in ³
cm ³ (cc)	0.0610	in ³
m ³	35.314	ft ³
ℓ	0.0353	ft ³
ℓ	0.2642	gal (US)
Weight:		
g	0.0353	oz
kg	2.2046	lb
Force:		
gf	2.205x10 ⁻³	lbf
kgf	2.2046	lbf
N	0.2248	lbf
Torque:		
N-m	0.7375	ft-lb
kg-m	7.223	ft-lb
Pressure:		
mm (H ₂ O)	0.00142	psi
mm (Hg)	0.0193	psi
torr	0.0193	psi
kPa	0.145	psi
bar	14.5	psi
kgf/cm ²	14.224	psi
MPa	145.0	psi
Energy:		
N-m	0.7375	ft-lb
J	0.7375	ft-lb
MJ	0.2778	kWh
Power:		
W	0.7376	ft-lb/s
kW	1.341	hp
Flow Rate:		
ℓ/min ANR	0.035	SCFM
Flow Coefficient:		
mm ²	0.0556	Cv
Temperature: °F = (1.8 x °C) + 32		

English to Metric

Multiply ▽	By ▽	To Obtain ▽
Length:		
mil	25.4	µm
in	25.4	mm
in	2.54	cm
ft	0.3048	m
Area:		
in ²	645.16	mm ²
in ²	6.4516	cm ²
ft ²	0.0929	m ²
Volume:		
in ³	16387	mm ³
in ³	16.387	cm ³ (cc)
ft ³	0.0283	m ³
ft ³	28.329	ℓ
gal (US)	3.785	ℓ
Weight:		
oz	28.349	g
lb	0.4536	kg
Force:		
lbf	453.6	gf
lbf	0.4536	kgf
lbf	4.4482	N
Torque:		
ft-lb	1.3559	N-m
ft-lb	0.1383	kg-m
Pressure:		
in (H ₂ O)	0.00254	kgf/cm ²
in (Hg)	0.03518	kgf/cm ²
psi	6.8947	kPa
psi	0.06894	bar
psi	0.0703	kgf/cm ²
psi	0.00689	MPa
Energy:		
ft-lb	1.356	N-m
ft-lb	1.356	J
kWh	3.6	MJ
Power:		
ft-lb/s	1.356	W
hp	0.7457	KW
Flow Rate:		
SCFM	28.3	ℓ/min ANR
Flow Coefficient:		
Cv	18	mm ²
Temperature: °C=5/9 (°F -32)		

Fractional / Decimal / Millimeter Conversion Chart

1mm = 0.03937" 0.01" = 0.254mm 1" = 25.4mm

Inch	Decimal	mm
1/64	0.016	0.397
1/32	0.031	0.794
3/64	0.047	1.191
1/16	0.063	1.588
5/64	0.078	1.984
3/32	0.094	2.381
7/64	0.109	2.778
1/8	0.125	3.175
9/64	0.141	3.572
5/32	0.156	3.969
11/64	0.172	4.366
3/16	0.188	4.763
13/64	0.203	5.159
7/32	0.219	5.556
15/64	0.234	5.953
1/4	0.25	6.35
17/64	0.266	6.747
9/32	0.281	7.144
19/64	0.297	7.541
5/16	0.313	7.938
21/64	0.328	8.334

Inch	Decimal	mm
11/32	0.344	8.731
23/64	0.359	9.128
3/8	0.375	9.525
25/64	0.391	9.922
13/32	0.406	10.319
27/64	0.422	10.716
7/16	0.438	11.113
29/64	0.453	11.509
15/32	0.469	11.906
31/64	0.484	12.303
1/2	0.5	12.7
33/64	0.516	13.097
17/32	0.531	13.494
35/64	0.547	13.891
9/16	0.563	14.288
37/64	0.578	14.684
19/32	0.594	15.081
39/64	0.609	15.478
5/8	0.625	15.875
41/64	0.641	16.272
21/32	0.656	16.669

Inch	Decimal	mm
43/64	0.672	17.066
11/16	0.688	17.463
45/64	0.703	17.859
23/32	0.719	18.256
47/64	0.734	18.653
3/4	0.75	19.05
49/64	0.766	19.447
25/32	0.781	19.844
51/64	0.797	20.241
13/16	0.813	20.638
53/64	0.828	21.034
27/32	0.844	21.431
55/64	0.859	21.828
7/8	0.875	22.225
57/64	0.891	22.622
29/32	0.906	23.019
59/64	0.922	23.416
15/16	0.938	23.813
61/64	0.953	24.209
31/32	0.969	24.606
63/64	0.984	25.003

mm	Inch
0.1	0.0039
0.2	0.0079
0.3	0.0118
0.4	0.0157
0.5	0.0197
0.6	0.0236
0.7	0.0276
0.8	0.0315
0.9	0.0354
1	0.0394
2	0.0787
3	0.1181
4	0.1575
5	0.1969
6	0.2362
7	0.2756
8	0.3150

mm	Inch
9	0.3543
10	0.3937
11	0.4331
12	0.4724
13	0.5118
14	0.5512
15	0.5906
16	0.6299
17	0.6693
18	0.7087
19	0.7480
20	0.7874
21	0.8268
22	0.8661
23	0.9055
24	0.9449
25	0.9843

Pressure Conversions

PSI	kgf/cm ²	MPa	kPa	bar
5	.35	.03	34	0.34
10	.70	.07	69	0.69
11.6	.82	.08	80	0.80
15	1.0	.10	103	1.03
20	1.4	.14	137	1.37
21.8	1.5	.15	150	1.50
25	1.8	.17	172	1.72
29	2.0	.20	200	2.00
30	2.1	.21	206	2.06
35	2.5	.24	241	2.41
36	2.6	.25	250	2.50
40	2.8	.28	275	2.75
45	3.2	.31	310	3.10
50	3.5	.34	344	3.44
55	3.9	.38	379	3.79
60	4.2	.41	413	4.13
65	4.6	.45	448	4.48
70	4.9	.48	482	4.82
75	5.3	.52	517	5.17
80	5.6	.55	551	5.51
85	6.0	.59	586	5.86
90	6.3	.62	620	6.20
95	6.7	.66	655	6.55
100	7.0	.69	689	6.89
101.5	7.1	.71	700	7.00
105	7.4	.72	724	7.24
110	7.7	.76	758	7.58
115	8.1	.79	758	7.93
120	8.4	.83	827	8.27
125	8.8	.86	861	8.62
130	9.1	.90	896	8.96
135	9.5	.93	930	9.31
140	9.8	.97	965	9.65
145	10.2	1.0	1000	10.00
150	10.5	1.1	1034	10.34
215.6	15.3	1.48	1500	15.00

Cylinder Force Chart

Theoretical Force = Area x Pressure

Bore	Piston Area (in ²)	Operating Pressure (psi)					
		25 psi	50 psi	75 psi	100 psi	125 psi	150 psi
1/4" (6mm)	0.05	1 lbf	2 lbf	4 lbf	5 lbf	6 lbf	7 lbf
8mm	0.08	2	4	6	8	10	12
3/8" (10mm)	0.11	3	6	8	11	14	17
5/8" (16mm)	0.31	8	15	23	31	38	46
3/4" (20mm)	0.44	11	22	33	44	55	66
1" (25mm)	0.79	20	39	59	79	98	118
1 1/8"	0.99	25	50	75	99	124	149
30mm	1.10	27	55	82	110	137	164
1 1/4" (32mm)	1.23	31	61	92	123	153	184
1 1/2" (40mm)	1.77	44	88	133	177	221	265
1 3/4"	2.41	60	120	180	241	301	361
2" (50mm)	3.14	79	157	236	314	393	471
2 1/2" (63mm)	4.91	123	245	368	491	614	736
3 1/4" (80mm)	8.30	207	415	622	830	1037	1244
4" (100mm)	12.57	314	628	942	1257	1571	1885
4 1/2"	15.90	398	795	1193	1590	1988	2386
5" (125mm)	19.63	491	982	1473	1963	2454	2945
140mm	23.86	597	1193	1790	2386	2983	3579
6"	28.27	707	1414	2121	2827	3534	4241
160mm	31.16	779	1558	2337	3116	3896	4675
7" (180mm)	38.48	962	1924	2886	3848	4811	5773
8" (200mm)	50.27	1257	2513	3770	5027	6283	7540
10" (250mm)	78.54	1963	3927	5890	7854	9817	11781
12"	113.10	2827	5655	8482	11310	14137	16965

Note: Do not forget to apply safety factor of 0.7 for horizontal and 0.5 for vertical cylinder orientation.

Cylinder Speed vs. Flow Chart

Cylinder Bore (inches)

In/sec	1/2	3/4	1	1 1/2	2	2 1/2	3 1/4	4
1	.0014 .041	.0032 .091	.0058 .16	.013 .37	.023 .65	.036 1.0	.061 1.73	.092 2.6
2	.0029 .081	.0065 .18	.012 .33	.026 .74	.046 1.3	.072 2.0	.12 3.5	.18 5.2
3	.0043 .13	.0097 .28	.017 .5	.039 1.1	.11 3.0	.069 2.0	.18 5.2	.276 7.8
4	.0058 .16	.013 .37	.023 .65	.052 1.5	.092 2.6	.14 4.0	.24 6.9	.37 10.4
5	.0069 .21	.015 .46	.028 .83	.065 1.9	.11 3.3	.18 5.0	.3 8.6	.46 13.0
6	.0087 .25	.020 .56	.035 1.0	.078 2.2	.14 4.0	.22 6.1	.37 10.4	.55 15.6
7	.010 .28	.023 .44	.04 1.13	.091 2.6	.16 4.5	.25 7.1	.43 12.1	.64 18.2
8	.011 .33	.025 .73	.045 1.3	.10 3.0	.18 5.2	.29 8.1	.49 13.8	.74 20.8
9	.013 .36	.030 .82	.053 1.45	.12 3.3	.21 5.8	.32 9.1	.55 15.6	.83 23.4
10	.014 .36	.032 .91	.058 1.63	.13 3.7	.23 6.5	.36 10.1	.61 17.3	.92 26.0
11	.016 .44	.035 1.0	.063 1.78	.14 4.1	.25 7.1	.40 11.1	.67 19.0	1 28.6
12	.018 .49	.039 1.1	.07 1.8	.16 4.4	.28 7.8	.43 12.1	.73 20.8	1.1 31.2
13	.019 .53	.042 1.18	.075 2.10	.17 4.8	.30 8.4	.47 13.1	.79 22.5	1.2 33.8
14	.02 .57	.045 1.28	.08 2.28	.18 5.2	.32 9.1	.50 14.1	.85 24.2	1.3 36.4
15	.021 .61	.048 1.36	.085 2.43	.19 5.6	.34 9.7	.54 15.1	.91 25.9	1.4 39.0
16	.023 .65	.052 1.46	.093 2.6	.20 5.9	.37 10.4	.58 16.2	.98 27.7	1.5 41.6
17	.024 .69	.055 1.55	.096 2.75	.22 6.3	.39 11.0	.61 17.2	1.0 29.4	1.6 44.2
18	.026 .73	.058 1.65	.103 2.93	.230 6.6	.41 11.7	.65 18.2	1.1 31.1	1.7 46.8
19	.028 .77	.062 1.73	.11 3.08	.25 7.0	.44 12.3	.68 19.2	1.2 32.8	1.75 49.4
20	.029 .81	.065 1.83	.12 3.25	.26 7.4	.46 13.0	.72 20.2	1.25 34.6	1.8 52.0
22	.032 .89	.072 2.01	.13 3.58	.29 8.1	.51 14.3	.79 22.2	1.3 38.1	2.0 57.2
24	.034 .98	.077 2.19	.14 3.90	.31 8.9	.55 15.6	.86 24.2	1.5 41.5	2.2 62.4
26	.037 1.06	.084 2.38	.15 4.23	.34 9.6	.60 16.9	.94 26.3	1.6 45.0	2.4 67.6
28	.04 1.14	.09 2.56	.16 4.55	.36 10.3	.64 18.2	1.0 27.3	1.7 48.4	2.6 72.8
30	.069 1.22	.097 2.74	.17 4.88	.39 11.1	.69 19.5	1.1 30.3	1.8 51.9	2.8 78.0

Cv Required at the cylinder Top / SCFM Lower: Cv based on 70 psi inlet and 10 psi pressure drop.

Note: This chart does not take into account the flow restrictions through the valve and tubing, etc..

Formulas

Area (in²) = diameter² x 0.7854 or πr^2

Circumference = $\pi D = 2\pi r$

Pressure = Force / Area

Force = Pressure • Area

Cylinder Volume (Head end) = Piston Area • Stroke

Cylinder Volume (Rod end) = (Piston Area - Rod Area) • Stroke

Compression Ratio (C.R.) = (psig + 14.7) / 14.7

Consumption (Standard ft³) = (Area in² x Stroke in x Compression Ratio) / 1728

Air Demand (scfm) = 60 x Area in² x Piston Speed in/s x C.R.) / 1728

Peak Air Flow (Q) = Volume / Time • C.R.

Torque = Force • Perpendicular distance from shaft

Water Weight = Pounds = US Gallons x 8.3453

$\pi = 3.14$, D = Diameter, r = Radius

Valve Sizing

Use the formula below with the cylinder flow chart above and the Compression Ratio and Pressure Drop Factor chart below to calculate the required Cv for a valve.

$$C_v = \frac{\text{Piston Area (in}^2\text{) x Stroke (in) x Compression Ratio}}{\text{Pressure Drop Factor x Stroke Time (sec) x 29}}$$

Inlet Pressure	Compression Ratio	Pressure Drop Factors for Various Pressure Drops				
		2 psi	5 psi	10 psi	15 psi	20 psi
10	1.7	6.5				
20	2.4	7.8	11.8			
30	3.0	8.9	13.6	18.0		
40	3.7	9.9	15.3	20.5	23.6	
50	4.4	10.8	16.7	22.6	26.4	29.0
60	5.1	11.7	18.1	24.6	29.0	32.0
70	5.8	12.5	19.3	26.5	31.3	34.8
80	6.4	13.2	20.5	28.2	33.5	37.4
90	7.1	13.9	21.6	29.8	35.5	39.9
100	7.8	14.5	22.7	31.3	37.4	42.1
110	8.5	15.2	23.7	32.8	39.3	44.3
120	9.2	15.8	24.7	34.2	41.0	46.4
130	9.8	16.4	25.6	35.5	42.7	48.4
140	10.5	16.9	26.5	36.8	44.3	50.3

Note: Pressure drop factor is based on the inlet pressure of the valve and the allowable pressure drop across the valve. For average conditions use a 70 psi inlet pressure and a 10 psi pressure drop.

Note: For more accurate valve sizing, particularly when temperature is a factor, or the operation is speed critical, use the following procedure.

Valve Selection

Something to remember when choosing which equation to use for valve selection

1. In many instances temperature is not a factor in system applications. In most industrial application, compressed air temperature is roughly the same as ambient. If this is the case, then the use of equation #1 is recommended. This equation has been widely accepted to get a Cv value.
2. If temperature is a factor in the application then equation #2 is recommended. We have chosen to use the constant 22.48 in our equations, but those who choose to be more conservative may choose use 22.67 as the constant. Both tied to ambient temperature.
3. When sizing a valve by calculating the Cv value, determining the pressure drop across the valve (i.e. ΔP), is an important step. What has proven to be a good practice in calculating Cv is the following:
 - a. For general applications use 10 psi for the pressure drop.
 - b. When a more conservative approach is needed, use 5 psi for the pressure drop.
 - c. If cylinder and design factors are critical, then using a 2 psi drop will more conservatively size the valve.
4. Also remember that, for calculation purposes, whether P1 is given in PSIG or PSIA, P2 needs to be reflected in absolute or PSIA (i.e. P2a)
5. Lastly, we recognize that not all applications will have a supply pressure of a higher valve: thus it is suggested that if P1 is 60 PSI or less, a 5 PSI pressure drop across the valve be used to calculate the Cv value.

(Eq. 1) Simplified equation when temperature is not a factor

$$Cv = \frac{1.024 \times Q}{\sqrt{\Delta P \times P2a}}$$

Given: Cv = Flow coefficient
1.024 = Constant
Q = Peak Flow Rate in SCFM
 ΔP = Pressure drop across the valve
(See information above)
P2a = Down-stream (valve's outlet) pressure in PSIA

(Eq. 2) Equation used when temperature is a factor in system application

$$Cv = \left(\frac{Q}{22.48} \right) \sqrt{\frac{TR}{\Delta P \times P2a}}$$

Given: Cv = Flow coefficient
22.48 = Constant (22.7 is often used, but 22.48 will be used on the PS exam)
TR = Temperature in Rankin ($^{\circ}F + 460$)
Q = Peak flow retain SCFM
 ΔP = Pressure drop across the valve
(See information above)
P2a = Down-stream (valve's outlet) pressure in PSIA

Vacuum Cup Sizing

Use the theoretical lift force (Ft) table below to determine what size vacuum cup to use for an application. Practical lift force (Fp) should be calculated with the following formula. Use the safety factors (t) from the table.

$$F_p = F_t \times 1/t$$

PLANE OF CUP CONTACT	STATIC LOAD	DYNAMIC LOAD
Horizontal	t > 4	t > 4
Vertical	t > 4	t > 8

F _t (lbf)		Vacuum Pressure (InHg)							
Cup ø (mm)	Area (mm ²)	26"	24"	22"	20"	18"	16"	14"	12"
2	.031	.062	.057	.05	.049	.042	.037	.033	.029
4	.126	.245	.225	.207	.187	.170	.150	.132	.112
6	.283	.551	.509	.465	.423	.381	.340	.298	.254
8	.503	.979	.904	.829	.754	.677	.602	.527	.452
10	.785	1.53	1.41	1.29	1.18	1.06	.941	.825	.705
13	1.33	2.58	2.38	2.18	1.98	1.79	1.59	1.39	1.19
16	2.01	3.90	3.62	3.31	3.02	2.71	2.40	2.12	1.81
20	3.14	6.13	5.64	5.16	4.70	4.23	3.77	3.31	2.82
25	4.91	9.57	8.82	8.09	7.36	6.61	5.89	5.14	4.41
32	8.04	15.7	14.5	13.3	12.1	10.8	9.63	8.44	7.23
40	12.6	24.5	22.5	20.6	18.8	16.9	15.1	13.2	11.3
50	19.6	38.1	35.3	32.4	29.3	26.5	23.6	20.6	17.7

Note: If several cups are used simply add up the forces for each cup

Sizing Vacuum Ejectors

Step 1 – Determine values for adsorption response time. T_1 & T_2

P_{ave} = Vacuum pressure required.

Given: T_2 = Adsorption response time to 95% of P_{ave} . (Time Required by process)

Find: T_1 = Adsorption response time to 63% of P_{ave} . $T_1 = \frac{T_2}{3}$

Step 2 – Determine the total volume of your system by calculating component volumes and adding them together.

2a) Tube Volume V_t: (mm³)

$$V_t = \frac{\pi}{4} \times d^2 \times \frac{L}{1000}$$

Where:

V_t = tube volume (mm³)

d = ID of tube (mm)

L = Length of tube (m)

Sizing Vacuum Ejectors

Step 2 – Determine the total volume of your system by calculating component volumes and adding them together. (Continued)

2b) Pad Volume V_p (if significant): (mm³)

$$V_p = \frac{\pi}{4} \times d^2 \times L$$

Where:

V_p = pad volume (mm³)

d = ID of pad (mm)

L = Depth of pad (mm)

For bellows pads

$$V_{pb} = \frac{\pi}{4} \times A^2 \times Y$$

Where:

V_{pb} = pad volume (mm³)

A = Dimension A from chart ID of Pad (mm)

Y = Dimension Y from chart Depth of Pad (mm)

Model	A	B	D	H: M6 x 1					H: M8 x 1					K	L	Y	
				C	E	F	G	I	C	E	F	G	I				
ZPT20B	20	22	23.5		28.5		54.5				33.5		49.5		12	25	10.5
ZPT25B	25	27	24	3	29	25	55	8	3.5	34	15	50	12	16	28	10.5	
ZPT32B	32	34	29		34		60				39		55		19	37	14

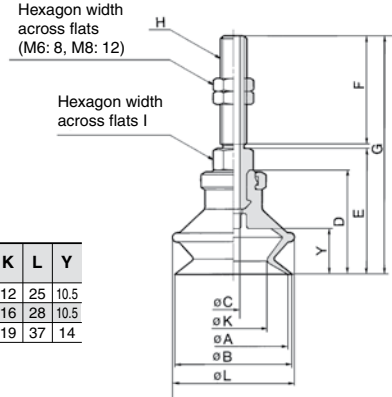

2c) Buffer Volume V_b (if present)

To approximate using C, G, & Y in the standard equation for volume:

$$V_p = \frac{\pi}{4} \times C^2 \times (G-Y)$$

2d) Filter Volume V_f (if present) (mm³)

Consult Best Pneumatics (for example):

$$AMJ3000 = 30cc \times 1000 = 30,000 \text{ mm}^3$$

$$AMJ4000/5000 = 85cc \times 1000 = 85,000 \text{ mm}^3$$

Or calculate approximate filter volume by dimensions from the catalog.

(Note that dimensions are not always given for the ID of the filter, so estimate can be used)

$$V_f = \frac{\pi}{4} \times d^2 \times h$$

Where:

V_f = filter volume (mm³)

d = ID of filter (mm)

h = height of filter (mm)

2e) Add component volumes together (mm³)

$$V_{total} = V_t + V_p + V_b + V_f + V_{misc}$$

2f) Convert from mm³ to Liters

$$V_{total} \text{ (mm}^3\text{)} \times \frac{1 \text{ (Liter)}}{1,000,000 \text{ (mm}^3\text{)}} = V_{total} \text{ (Liters)}$$

Sizing Vacuum Ejectors

Step 3 – Determine the mean vacuum flow, Q_1 (liter/mm)

$$Q_1 = \frac{V_{\text{total}}}{T_1} \times \frac{60 \text{ sec}}{1 \text{ min}}$$

Where: Q_1 = Average flow required (L/min)
 V_{Total} = Volume of to be evacuated (liters)

Step 4 – Determine Leakage, Q_L (Liter/min) and Q_{max} (liter/min)

Connect pad to a test ejector and vacuum pressure gauge. Operate ejector at recommended supply pressure and place pad on work piece.

Note the vacuum pressure achieved and compare it to chart from the catalog for the ejector.

If the pressure gauge shows full vacuum pressure achieved, then there is no leakage.

Then use $Q_{\text{max}} = 2 \times Q_1$

If the pressure gauge shows less than full vacuum pressure achieved, determine Q_L by finding pressure achieved on graph. Move to the right until intersecting diagonal line above the Q_L flow rate

Then use $Q_{\text{max}} = 3 \times (Q_1 + Q_L)$

Flow Characteristics

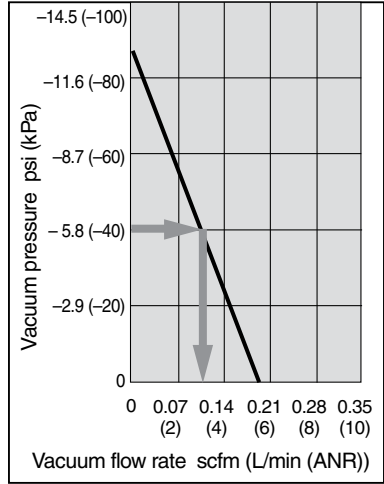

Step 5 – Choose ejector.

Choose an ejector that meets the physical characteristics, optional features and Q_{max} flow rate that will perform adsorption in the given time. T_2



ZM

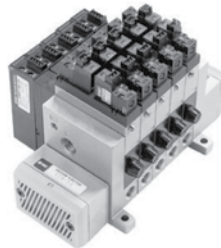

ZZM



ZH

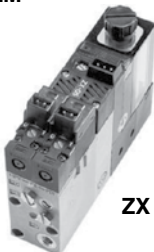

ZX



ZL212

Pipe Thread Quick Reference

Tapered pipe threads seal at the points where the crests of the threads meet the roots of the mating threads. Standard pipe threads, NPT, PT, and BSPT require sealant to prevent the development of a spiral leak path. NPTF threads are designed to crush the points of the crests into the roots of the mating threads to achieve the same purpose, however, use of a lubricant or sealant to prevent galling of the threads is preferred where not functionally prohibited.

BSPT – British Standard Taper Pipe Threads

PT – Japanese Industrial Standard Taper Pipe Threads

{R (PT)} – Taper external threads

{Rc (PT)} – Taper internal threads

NPT – American National Standard Taper Pipe Threads

*All of the above are designed to be used with sealant to provide a pressure tight joint.

NPTF – American National Standard Dry seal Pipe Threads

*Designed to provide a pressure tight joint without the use of sealant.

PF – Japanese Industrial Standard Parallel Pipe Threads

*Straight threads use a gasket or O-ring to produce a pressure tight joint.

Basic Dimensions

Port Size	PT & BSPT				NPT & NPTF			
	Threads per inch	Pitch	Major Dia.	Thread form angle	Threads per inch	Pitch	Major Dia.	Thread form angle
1/16	28	.03571	.304	55°	27	.030704	.313	60°
1/8	28	.03571	.383	55°	27	.030704	.404	60°
1/4	19	.05262	.518	55°	18	.05556	.540	60°
3/8	19	.05262	.656	55°	18	.05556	.675	60°
1/2	14	.07142	.825	55°	14	.07143	.840	60°
3/4	14	.07142	1.041	55°	14	.07143	1.050	60°

Compatibility between the above male and female is outlined below. SMC Corporation, however, has the unique solution to all this complexity. The Uni-Fit will screw into all major thread variations.

		Female								
		Parallel				Taper			American	
		BSP	Rp	PF	G	BSPT	Rc	PT	NPT	NPTF
Male	BSP	Y	Y	Y	Y	N	N	N	N	N
	BSPT	Y	Y	Y	Y	Y	Y	Y	N	N
	G	Y	Y	Y	Y	N	N	N	N	N
	NPT	N	N	N	N	N	N	N	Y	N
	NPTF	N	N	N	N	N	N	N	N	Y
	PF	Y	Y	Y	Y	N	N	N	N	N
	PT	Y	Y	Y	Y	Y	Y	Y	N	N
	R	Y	Y	Y	Y	Y	Y	Y	N	N
UNI	Y	Y	Y	Y	Y	Y	Y	Y	Y	

Miniature threads, **M5x0.8** and **10/32 UNF**, will only mate as follows: **10/32** male will fit into and **M5** female, **M5** male will **NOT** fit into a **10/32** female. Both of these threads use a gasket to produce a pressure tight fit.

Installation Guide for Valves

“Standard ISO port call out”

Port ID	Description of Function
1	Inlet – Supply Pressure {Port P}
2	Output – Normally Open at rest (Unless specified in a 2 or 3 port valve) (1 → 2) {Port B}
4	Output – Normally Closed at rest (4 → 5) {Port A}
3 & 5	Exhaust ports {Port EA & EB}
X	External Pilot Supply (Used to supply pilot for low pressure or vacuum applications)
EX	Pilot Exhaust (Never plug. Leave open or use a silencer)

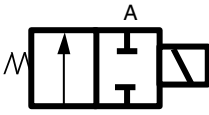

**2 Port/ 2 Position
Normally Closed**

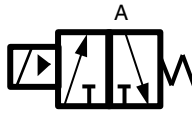

3 Port/ 2 Position

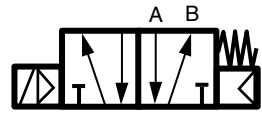

5 Port/ 2 Position

Each square represents a position or state that the valve will perform. The square that has the call outs will always show the valve at rest.

At Rest Action

2 port NC	P → Blocked	A → Blocked	
2 port NO	P → A		
3 Port NC	P → Blocked	A → E	
3 Port NO	P → A	E → Blocked	
5 Port / 2 Position	P → B	A → EA	EB → Blocked
5 Port / 3 Position – Closed	P, B & A → Blocked	EA & EB → Blocked	
5 Port / 3 Position – Exhaust	P → Blocked	B → EB	A → EA
5 Port / 3 Position – Open	P → B & A	EA & EB → Blocked	

Directional Control Valves

Valve Functions

A directional control valve determines the flow of air between its ports by opening, closing or changing its internal connections. The valves are described in terms of: the number of ports, the number of switching positions, its normal (not operated) position and the method of operation. The first two points are normally expressed in the terms 5/2, 3/2, 2/2 etc. The first figure relates to the number of ports (excluding pilot ports) and the second to the number of positions.

The main functions and their ISO symbols are:

Symbol	Principal Construction	Function	Application
		2/2 ON/OFF without exhaust.	Air motors and pneumatic tools
		3/2 Normally closed (NC), pressurizing or exhausting the output A	Single acting cylinders (push type), pneumatic signals
		3/2 Normally open (NO), pressurizing or exhausting the output A	Single acting cylinders (pull type), inverse pneumatic signals
		4/2 Switching between output A and B, with common exhaust	Double acting cylinders
		5/2: Switching between output A and B, with separate exhausts.	Double acting cylinders
		5/3, Open center: As 5/2 but with outputs open to exhaust in mid-position	Double acting cylinders, with the possibility to de-pressurize the cylinder
		5/3 Closed center: As 5/2 but with mid-position fully shut off	Double acting cylinders, with stopping possibility
		5/3 Pressurized center:	Special applications, i.e. Locking or Rodless Cylinder

Valve Symbols, Principles, description and main applications

Directional Control Valves

Port Identification

The denominations or nomenclature used to identify the various ports was not uniform until the 5/2 and 5/3 valves were invented. Until the 5/2 and 5/3 were invented, there was more tradition than any respected standard.

Originally, the codes previously used for older hydraulic equipment were adopted. "P" for the supply port comes from "pump", the hydraulic source of fluid energy, and is understood to mean "pressure" in pneumatic systems.

The outlet of a 2/2 (two ports, two positions) or 3/2 valve has always been "A", with the second, antivalent output port labeled "B".

The exhaust port was originally labeled "R" from Return (to the oil tank). We can think of R as return to atmosphere in pneumatic systems. The second exhaust port in 5/2 valves was sometimes named S, or

the former "R1" and the latter "R2".

The pilot port initiating the power connection to port A has originally been coded "Z" (the two extreme letters in the alphabet belongs together) and the other "Y".

After 20 years of bargaining about pneumatic and hydraulic symbols, one of the ISO work groups had the idea that ports should have numbers instead of letters, thus delaying the termination of the standard ISO 1219 by another 6 years. Supply should be "1", the outputs "2" and "4", the pilot port connecting "1" with "2" is then "12" etc. Table A shows the main sets of port identifications in use. Preferred are now the ISO 5599 numbers.

Standard	Supply Port	NC output	NO output	Exhaust of NC	Exhaust of NO	Pilot for NC	Pilot for NO
Old JIS	P	A	B	R	S	Z	Y
ISO 1219	P	A	B	R	S	Z	Y
JIS	P	A	B	R1	R2	Z	Y
JIS	1	4	2	5	3	14	12
NFPA	P	A	B	EA	EB	PA	PB
ISO 5599	1	4	2	5	3	14	12
SMC	P (1)	A (4)	B (2)	EA (5)	EB (3)	PA (14)	PB (12)

Table A Typical port identifications

Monostable And Bi-stable

Spring returned valves are monostable (stable in one default or preferred condition). They have a defined preferred position to which they automatically return. A bi-stable valve has no preferred position and remains in either position until one of its two impulse signals are operated.

Valve Types

The two principal methods of construction are Poppet and Slide with either elastic (rubber) or metal seals. Fig. B relates to the various combinations.

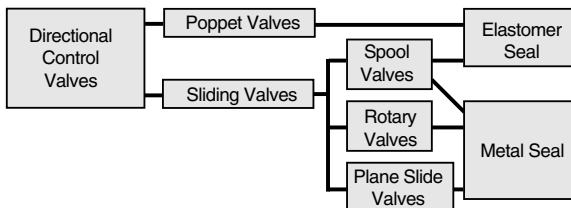

Fig. B The various types of valves and sealing methods

Product Data Codes

Acronyms for Materials

C3604	Copper alloy per JIS H 3250 type C 3604
CR	Neoprene
EPR	Ethylene-propylene rubber
FKM	Fluorocarbon or Fluoro Elastomers (Viton)
NBR	Buna N or Nitrile rubber
PBT	Polybutylene terephthalate
POM	Polyacetal (Delrin)
PP	Poly-propylene
Si	Silicone rubber

SL	Silicone rubber
SPC	Cold roll steel
SUS	Stainless steel
SUS304	304 grade stainless steel
SUS316	316 grade stainless steel
SWP-B	Piano wire
SWRM3	Low Carbon steel wire rod
TF	Polytetrafluoroethylene (Teflon)
PFA	Moldable Teflon

Indication of International Standard Code for Production Lot No.

Annual Code		Monthly Code		Country Code	
Year	Variable Code 1st digit	Month	Fixed Code 2nd digit	Company	Fixed Code 3rd & 4th digits
1996	A	January	O	SMC-JAPAN	Nil
1997	B	February	P	SMC-USA (INDY)	I
1998	C	March	Q	SMC-CANADA	CA
1999	D	April	R	SMC-MEXICO	MX
2000	E	May	S	SMC-ARGENTINA	AR
2001	F	June	T	SMC-CHILE	CL
2002	G	July	U	SMC-SWITZERLAND	CH
2003	H	August	V	SMC-GERMANY	DE
2004	I	September	W	SMC-UK	GB
2005	J	October	X	SMC-IRELAND	IE
2006	K	November	Y	SMC-ITALY	IT
2007	L	December	Z	SMC-FRANCE	FR
2008	M			SMC-SWEDEN	SE
2009	N			SMC-AUSTRIA	AT
2010	O			SMC-SPAIN	ES
2011	P			SMC-TIWAN	TW
2012	Q			SMC-SINGAPORE	SG
2013	R			SMC-manufacturing (SP)	Nil
2014	S			SMC-HONG KONG	HK
2015	T			SMC-PHILIPPINE	PH
2016	U			SMC-MALAYSIA	MY
2017	V			SMC-KOREA	KR
2018	W			SMC-CHINA	Nil
2019	X			SMC-THAILAND	TH
2020	Y			SMC-INDIA	IN
2021	Z			SMC-AUSTRALIA	AU
2022	A			SMC-NEW ZEALAND	NZ
2023	B				

Note)

- Exception: Country code is not available for SMC- Japan, SMC-China and SMC Manufacturing (Singapore).
- Exception: Country code is not available for SMC US, instead use [1] for Indianapolis factory.
- If 2 or more production facilities will exist in future, add number of facilities after this code in order of registration.
- In case of necessity of additional information, Job No. etc., add them after this code.

1st digit Variable Annual Code
(Start [A] from 1996 to [Z], then return [A])

2nd digit Fixed Monthly Code

3rd & 4th digitals Fixed Country Code
(Based on ISO -3166, Common Country Code)

For example:
Production in Italy on November 1996 ...AYIT
Production in USA on May 2000 ... ESI

Cylinder Part Number Building Information

• Style? _____

• Bore? _____

• Stroke? _____

• Single or Double Acting?

• Spring return or spring extend?

Mounting? _____

Inch or Metric?

Auto - Switch Capable? Y or N

• Number of Switches? _____

• Reed or Solid State? NPN or PNP?

• What Voltage? _____

• Standard or Long Leads?

• Prewired lead connector?

Options

• Oversize rod?

• Cushions? Air or Urethane?

• Non-rotating rod?

• Rod boot? Nylon or Neoprene?

• Low or High Temp application?

• Low Friction?

• Stainless Steel Rod?

• Adjustable Stroke? Extend or Retract?

• Dual Stroke? Single or Double Rod?

• Extended rod? Inch or Metric?

• Extended rod threads? Inch or Metric?

• Special Rod threads?

Accessories

• Rod Eye

• Double Rod Clevis

• Flange (Head or Rear)

• Single Rod Clevis

• Foot Bracket

• Trunnion

Speed _____ Load _____ Mounting Direction _____

Temperature _____ Environment _____

Moments: X _____ Y _____ Z _____

Note: Use cylinder dimensional sketch on page 19, if necessary.

Crossing Over a Cylinder

Bore _____ Stroke _____ Inch or Metric Port Size _____

Thread Size _____ Mounting Style _____

Line Pressure _____ Load _____

Vertical or Horizontal Lift _____ Switches _____ Style _____

Dimensions:

A _____ B _____ C _____ D _____

E _____ F _____ G _____

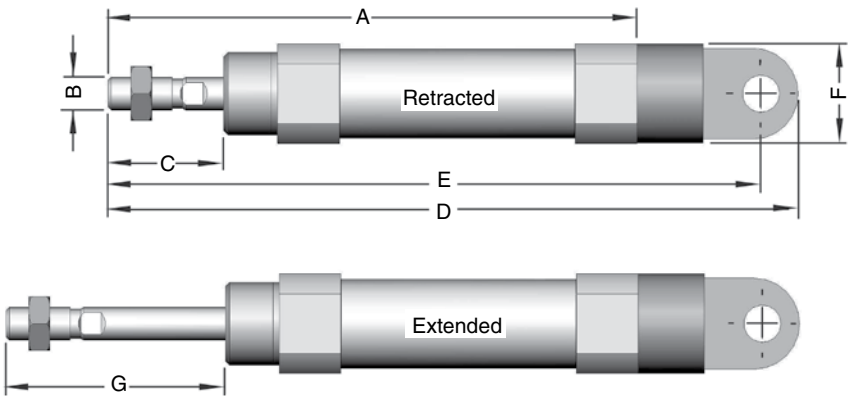

$$\text{Stroke} = C - G$$

Valve Part Number Building Information

- How Many Ports? _____
- How Many Positions? _____
- Flow? _____
- Rubber or Metal Seal? _____
- What is the application? _____
 - Cylinder bore? _____ Stroke? _____
 - Speed? _____ Blow off? _____
- Single or Double Solenoid? _____
- Voltage? _____
- Style of Connector? _____
 - Plug-In, DIN or Grommet?
 - Serial or Discrete?
- Body Ported, Sub-plate or Manifold?
- Foot bracket, Mounting holes or DIN Rail?
- Port Size? _____ Threaded or One Touch Fitting
- How Many Stations? _____
- Operating Pressure? _____
- Temperature? _____
- Environment? _____

Vacuum Order Sheet

- Ejector - Single stage, 2-stage or 3-stage nozzle?
- Port size? _____
- Flow? _____
- Application:
 - Horizontal or Vertical Lift?
 - Load Material? _____
 - Weight of Load? _____
 - Number of Pads? _____
 - Surface Material? _____
 - Pad Diameter? _____
 - Flat, Flat w/ Ribs, Deep or Bellows?
 - Material? _____
 - Connection – Vertical or Horizontal Vacuum entry?
 - Buffer or Non – Buffer?
 - Female Fitting, Barb or One-Touch?
 - Vacuum Pressure? _____
- Vacuum Filter? _____
- Solenoid Valves for Supply and/or Blow off?
 - Voltage? _____
 - Type of connector, Grommet, L type, M type?
- Individual or Manifold?
- Vacuum Switch or Adsorption Conformation?
PNP or NPN?

Auto Switches

REED SWITCHES: A thin metal contact is drawn closed by the magnetic field of the piston magnet. Since this is a mechanical switch it will wear out over time and is susceptible to vibration and shock. Their advantage is that they are inexpensive and can be used with AC voltages.

SOLID- STATE SWITCHES: The magnetic field generated by the piston magnet causes a current flow inside the switch. Since there are no moving parts, the switch life is much longer than a reed switch and they are less prone to vibration and shock. They are more expensive, can only be used with DC voltages and you need to know whether you need a sinking or sourcing switch.

Current Sinking (NPN) –The switch sensor “sinks” current from the load through the sensor to ground. The load is connected between the positive voltage supply and the output lead of the sensor.

3-Wire NPN Sensor Connection

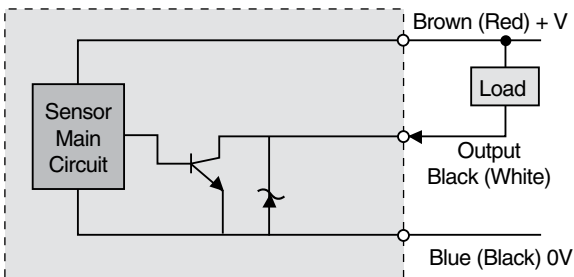

Current Sourcing (PNP) – The switch sensor “Sources” current through load to ground. The load is connected between the output lead of the sensor and the negative “ground” lead of the supply.

3-Wire PNP Sensor Connection

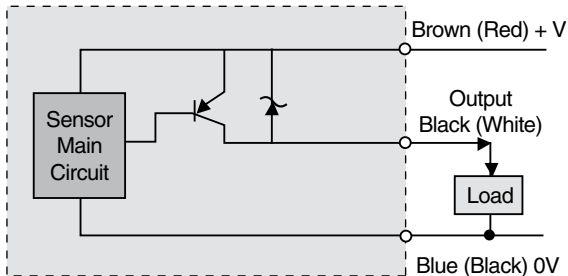

Three wire DC sensors include one wire that provides voltage to the sensor, an output signal wire and a ground wire. Most electro-mechanical loads (relays, counters, solenoids etc.) can use either a sink or source type switch provided it is wired properly. The proper sensor type must be chosen when used with solid-state load and programmable controllers due to the fact that some of these loads must be grounded.

Wire Colors: SMC has changed the wire colors on all of our switch products. This was done to conform to European standards that are being adopted worldwide.

Positive	Red	} (old colors)	Brown	} (new colors)
Negative	Black		Blue	
Output	White		Black	

Pressure Switches and Their Simplified Operation

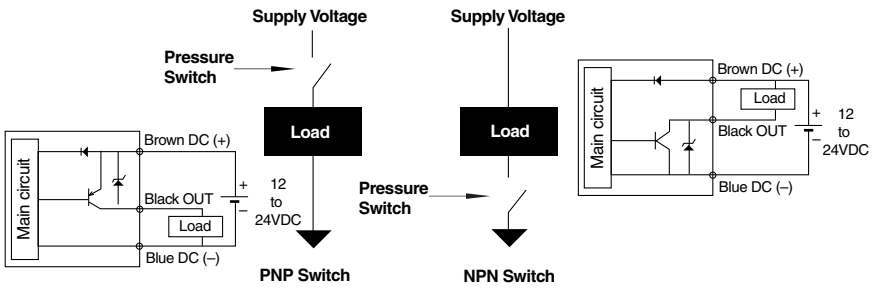

Sourcing – PNP is often referred to as Sourcing, because the switch closes and provides the source voltage to the load

Sinking – NPN is often referred to as Sinking, because the switch closes and sinks the current to ground

Normally Open – Does not pass the signal until the set point is reached

Normally Closed – Passes current until the set point is reached

FS or Full Scale – The maximum setting minus the minimum setting.

Ex. ITV1050 0.9MPa – 0.005MPa = 0.895 MPa Full Scale
(130.5 psi – 0.725 psi = 129.775 psi)

Linearity – The nearness with which the plot of a signal, or variable, plotted against a prescribed linear scale approximates a straight line. Output error to reference value

Repeatability – The ability of the instrument to provide the same output every time for the same input. Usually given as a % of the FS value

Sensitivity – Often described as the minimum change of input to which the system is capable of responding. Usually expressed in % of Full Scale

Hysteresis – The difference in output when the measured value is first approached with increasing and then decreasing values. Expressed in % of Full Scale

Impedance – Resistance of a load that hinders the flow.

Current Consumption – The amount of current needed for normal operation, does not include load current.

Watts (W) and Volt Amps (VA) – Both of these units are used to express electrical power.

Watts is for DC voltage and Volt Amps is for AC voltage.

If you have any questions on basic electronics there is an entry in the Product Application Database that explains basic electronics.

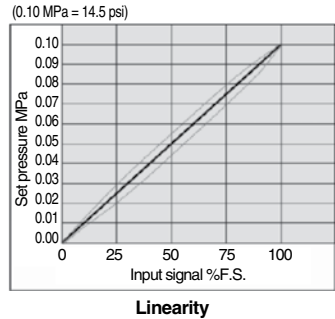

This graph shows the repeatability of an analog output, pressure display and a switch (ON-OFF) output's moving point. The pressure is increased or decreased under normal temperature (77°F (25°C)).

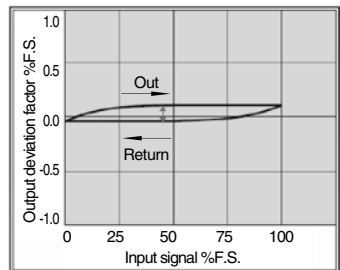
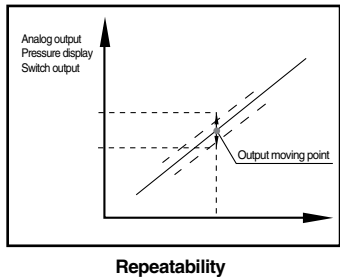

NEMA Ratings (Electrical Enclosures)

An enclosure is a surrounding case constructed to provide a degree of protection to personnel against accidental contact with the enclosed equipment and to provide a degree of protection to the enclosed equipment against specified environmental conditions. These are the more common classifications as they pertain to pneumatic components such as valves.

NEMA 1 Intended for Indoor use primarily to provide a degree of protection against contact with enclosed equipment.

NEMA 2 Intended for indoor use primarily to provide a degree of protection against limited amounts of falling water and dirt.

NEMA 3 Intended for outdoor use to provide a degree of protection against windblown dust, rain, sleet and external ice formation.

NEMA 3R Intended for outdoor use to provide a degree of protection against falling rain, sleet and external ice formation.

NEMA 3S Intended for outdoor use to provide a degree of protection against windblown dust, rain, sleet and provide for operation of external mechanisms when ice laden.

NEMA 4 Intended for indoor and outdoor use primarily to provide a degree of protection against windblown dust and rain, splashing water and hose directed water.

NEMA 4X Intended for indoor and outdoor use primarily to provide a degree of protection against corrosion, windblown dust and rain, splashing water and hose directed water.

NEMA 6 Intended for indoor or outdoor use primarily to provide a degree of protection against entry of water during occasional submersion to a limited depth.

IP Ratings (Electrical Enclosures)

1 st Numeral: Degree of protection with respect to persons and solid objects	2 nd Numeral: Degree of protection with respect to harmful ingress of water								
	Non protected	Dripping water	Dripping water +/- 15°	Spraying water +/- 60°	Splashing water 360°	Water jets	Heavy seas	Immersion	Submersion
Not protected	0	IP00	IP01	IP02					
Solid objects > ø50mm	1	IP10	IP11	IP12	IP13				
Solid objects > ø12mm	2	IP20	IP21	IP22	IP23				
Solid objects > ø2.5mm	3	IP30	IP31	IP32	IP33	IP34			
Solid objects > ø1.0mm	4	IP40	IP41	IP42	IP43	IP44	IP 45	IP 46	
Dust protected	5					IP54	IP 55	IP 56	
Dust tight	6						IP 65	IP 66	IP 67
									IP 68

Note: find IP rating and follow across and up to find degree of combined protection. IP65 and NEMA 4 are roughly equivalent

Threaded Type

KQ2 H 05 - 34 A S

One-Touch Fittings Series KQ2

Model

Symbol	Model
H	Male connector
S	Hexagon socket head male connector
F	Female union
L	Male elbow
K	45° male elbow
V	Universal male elbow
VS	Hexagon socket head universal male elbow
VF	Universal female elbow
LF	Female elbow
VD	Double universal male elbow
VT	Triple universal male elbow
Z	Branch universal male elbow
ZD	Double branch universal male elbow
ZT	Triple branch universal male elbow
W	Extended male elbow
T	Male branch tee Union Tee Different diameter Tee
Y	Male run tee Branch "Y" Union "Y" Different diameter Union "Y"
U	Different diameter plug-in "Y"
X	Bulkhead union
E	Bulkhead connector
LE	Bulkhead union elbow
N	Adaptor

Male thread seal method

Symbol	Seal method
Nil	None
S	With thread sealant

Thread material/Surface treatment

Symbol	Thread material/Surface treatment
A	Brass (compatible with KQE)
N	Brass + Electroless nickel plated Compatible to KQE-X2
Bulkhead union	<input type="checkbox"/> J <input type="checkbox"/> A Interchangeable with KJE

* A, N

Port size/Applicable tubing O.D.

Symbol	Size
32	10-32UNF
33	NPT1/16
34	NPT1/8
35	NPT1/4
36	NPT3/8
37	NPT1/2
Tubing connection	00* Same diameter tubing

* Only for "Bulkhead union" and "Bulkhead union elbow".

Applicable tubing O.D.

Symbol	Size
01	ø1/8"
03	ø5/32"
05	ø3/16"
07	ø1/4"
09	ø5/16"
11	ø3/8"
13	ø1/2"

Spare Parts

Use the part number below to order the gasket for sealing 10-32UNF thread.
Gasket for 10-32UNF: M-10/32G

Tube - Tube Type

KQ2 H 05 - 00 A

One-touch fittings

Model

Symbol	Model
H	Straight Different diameter straight
L	Elbow Plug-in elbow Reducer elbow
R	Plug-in reducer
T	Union tee Different diameter tee
TW	Cross union
U	Union "Y" Plug-in "Y" Different diameter union "Y"

Port size/Applicable tubing O.D.

Symbol	Size	
00	Same diameter tubing	
99	Same diameter rod	
Tubing (Rod) connection Different dia. Tubing (Reducer)	01	ø1/8"
	03	ø5/32"
	05	ø3/16"
	07	ø1/4"
	09	ø5/16"
	11	ø3/8"
	13	ø1/2"

Applicable tubing O.D.

Symbol	Size
01	ø1/8"
03	ø5/32"
05	ø3/16"
07	ø1/4"
09	ø5/16"
11	ø3/8"
13	ø1/2"

Accessory

Symbol	Name
KQ2N	Nipple
KQ2C	Reducer nipple
KQ2P	Tube cap Plug

FRL Cheat Sheet

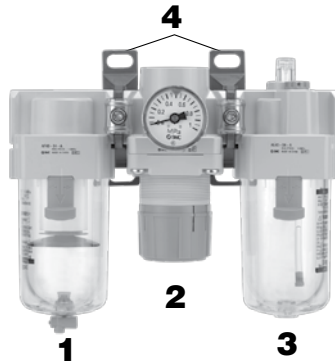

1. Filter



Port Size	Part No. W/ Manual Drain	Part No. W/Auto Drain
1/8" NPT	AF20-N01-CZ-A	AF20-N01C-CZ-A
1/4" NPT	AF20-N02-CZ-A	AF20-N02C-CZ-A
3/8" NPT	AF30-N03-Z-A	AF30-N03D-Z-A
1/2" NPT	AF40-N04-Z-A	AF40-N04D-Z-A
3/4" NPT	AF50-N06-Z	AF50-N06D-Z
1" NPT	AF60-N10-Z	AF60-N10D-Z

2. Regulator



Port Size	Part Number W/O gauge	Part Number W/gauge
1/8" NPT	AR20-N01H-Z-A	AR20-N01GH-Z-A
1/4" NPT	AR20-N02H-Z-A	AR20-N02GH-Z-A
3/8" NPT	AR30-N03H-Z-A	AR30-N03GH-Z-A
1/2" NPT	AR40-N04H-Z-A	AR40-N04GH-Z-A
3/4" NPT	AR50-N06H-Z	AR50-N06GH-Z
1" NPT	AR60-N10H-Z	AR60-N10GH-Z

3. Lubricator



Port Size	Part Number
1/8" NPT	AL20-N01-3CZ-A
1/4" NPT	AL20-N02-3CZ-A
3/8" NPT	AL30-N03-3Z-A
1/2" NPT	AL40-N04-3Z-A
3/4" NPT	AL50-N06-3Z
1" NPT	AL60-N10-3Z

4. Brackets



Air Prep Unit Port Size	Spacer	Spacer-T
1/8" NPT (AC20 Series)	Y200-A	Y200T-A
1/4" NPT (AC20 Series)	Y200-A	Y200T-A
3/8" NPT (AC30 Series)	Y300-A	Y300T-A
1/2" NPT (AC40 Series)	Y400-A	Y400T-A
3/4" NPT (AC50 Series)	Y500-A	Y500T-A
1" NPT (AC60 Series)	Y600	Y600T

U.S. & Canadian Sales Offices

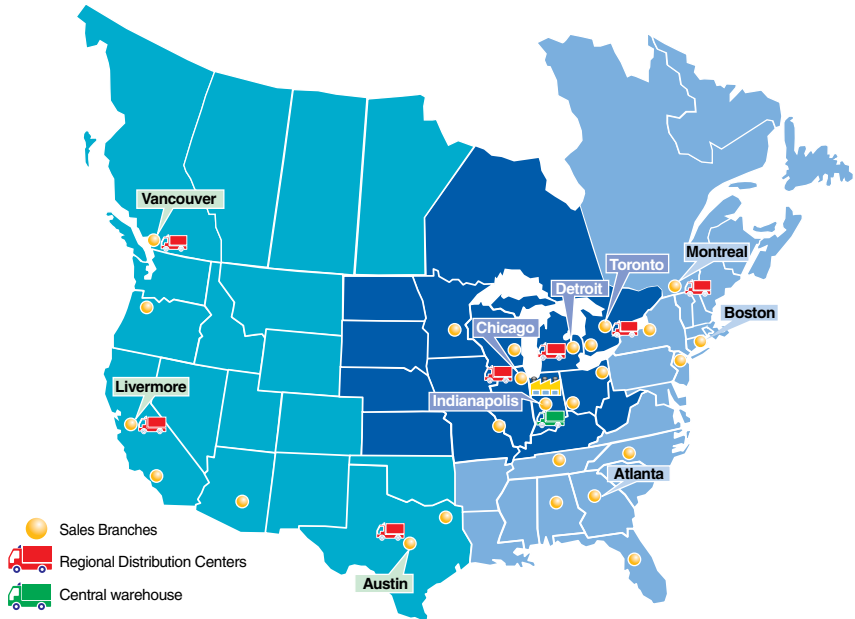

WEST

Austin
Dallas
Los Angeles
Phoenix
Portland
San Francisco
Vancouver

CENTRAL

Chicago
Cincinnati
Cleveland
Detroit
Indianapolis
Milwaukee
Minneapolis
St. Louis
Toronto
Windsor

EAST

Atlanta
Birmingham
Boston
Charlotte
Nashville
New Jersey
Rochester
Tampa
Montreal

With 360 sales offices in 78 countries worldwide, our sales force of over 5,700 maintains close communication with customers.



SMC Corporation of America
 10100 SMC Blvd., Noblesville, IN 46060
www.smcusa.com

SMC Pneumatics (Canada) Ltd.
www.pneumatics.ca

(800) SMC.SMC1 (762-7621)

e-mail: sales@smcusa.com

For International inquiries: www.smcworld.com